



FOR PRICE LISTING
GO TO PAGE 317

PLASMA CUTTING

Replacement Parts

Suitable For

Thermal Dynamics Corp.®

Torch Model	Power Supply Model
PCH/M-6B	PAK® 44, 45

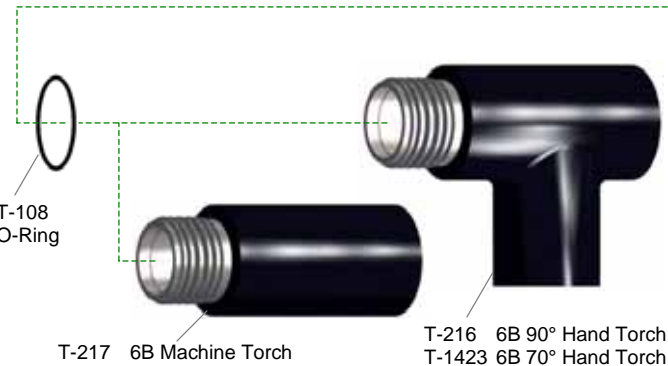
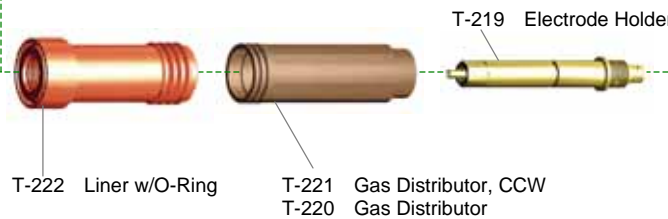
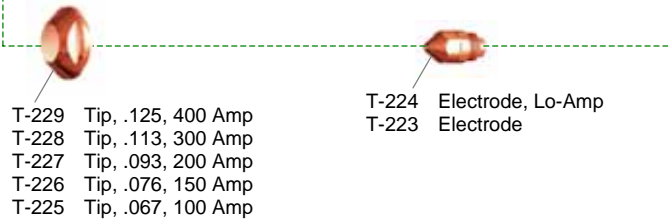
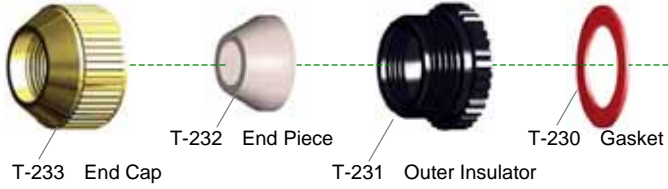

ITEMS NOT SHOWN

- T-236 Liner/Tip Wrench
- T-235 Electrode Wrench
- T-234 Electrode Holder Wrench

T-163 Lubricant



REQUIREMENTS:

Plasma Gas:	Setting	Consumption
N ₂	60 psi (4.2 kg/cm ²)	110 SCFH (52 lpm)
Ar/H ₂	40 psi (2.8 kg/cm ²)	100 SCFH (47 lpm)
Secondary	Setting	Consumption
CO ₂ , Ar/H ₂	40 psi	270 SCFH
Comp. Air	(2.8 kg/cm ²)	(127.4 lpm)
H ₂ O	15 gph (56 lph)	15 gph (56 lph)

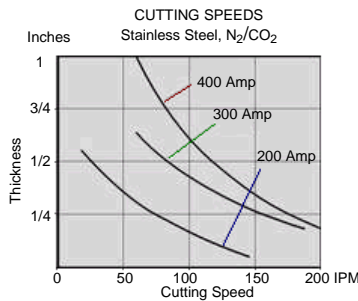

Accessories Suitable For

Thermal Dynamics Corp.®

Torch Model	Power Supply Model
PCH/M-6B	PAK® 44, 45

HAND TORCH

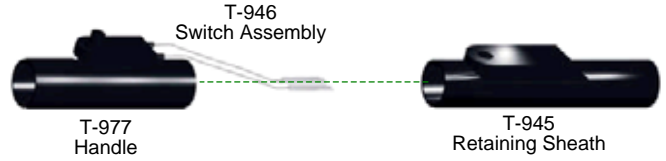

HAND TORCH

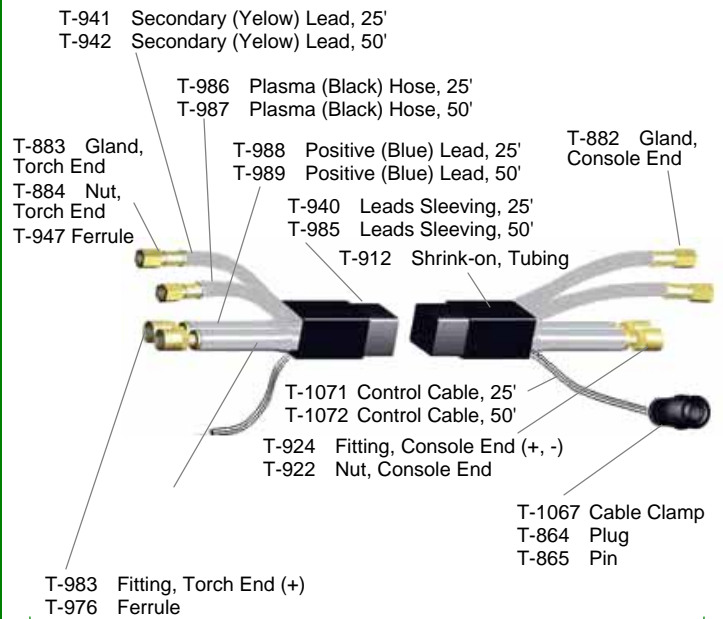
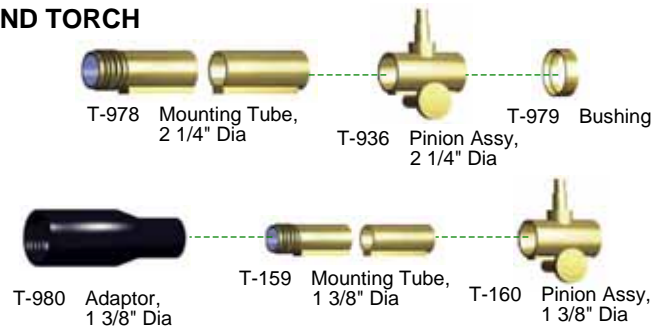

- T-932 Hand Leads, 25'
- T-933 Hand Leads, 50'
- T-934 Machine Leads, 25'
- T-935 Machine Leads, 50'

ITEMS NOT SHOWN

- T-981 Heat Shield, Machine
- T-982 Heat Shield, Hand